

Introduction

From patch-leads through to cross-site cables, or optical adapters through to patch panels, PPM's one-stop-shop approach to fibre optic cable management offers a range of various high performance solutions designed to facilitate the quick and easy installation of all its fibre optic link products.

Patch leads

Our range of single-mode patch-leads can be ordered in lengths ranging from 0.5m up to 1km long and are terminated at either end with corresponding optical connectors to mate between your fibre optic link system and/ or patch panel.

Can also be used to fusion splice to un-terminated fibre optic cables when used inside a Cable Termination Box (CTB)



Patch-lead specification table

Connector type	FC/APC	E2000/APC
Compliance	IEC 61754-13 TIA 604-4-A	IEC 61754-15 TIA 604-16
Insertion loss at 1300nm	0.4dB	0.4dB
Return loss	>65dB	>65dB
Fibre type	Single-mode 9/125µm SMF 28 tight buffered	
Jacket	Self-extinguishing LSFH, very low fire load for high safety.	
Jacket diameter (mm)	2.5 ~ 3.0	
Min bead radius (mm)		
• during installation	60	
• in service	30	

Patch-lead part number ordering information:

F 6 R1 / XXXX

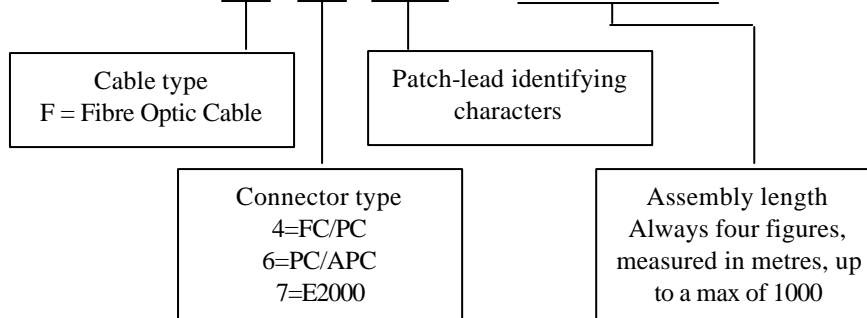

Cross Site Cables

To facilitate every possible on site installation requirement, PPM offers a range of fibre optic cross-site cabling solutions for customer specific indoor or outdoor applications. Choose between:

- Fully terminated indoor
- Fully terminated outdoor
- Un-terminated indoor
- Un-terminated outdoor

Fully terminated cross-site cable assembly (indoor and outdoor applications)

This solution can be installed within the shortest time via the use of dedicated waterproof and crush resistant pulling boots, fitted at one or both ends of the assembly. Each pulling boot protects the delicate fibre optic connectors during installation and can be readily removed once in situ, to offer the customer a virtual “plug - ‘n’-play” fibre optic cabling solution.

Installation is done without the need for any on-site splicing or testing due to the optical connectors being factory fitted prior to despatch. Each cable can accommodate up to 12 optical connectors – the required number being specified at time of order.



Un-terminated cross-site cable (indoor and outdoor applications)

Exactly the same cable type as utilised for the fully terminated cross-site cable can be supplied in varying lengths but without any optical connectors fitted. This solution would require the on site splicing of optical pigtails to the main fibre. The cable contains between 4 and 12 250µm optical fibres (dependant on cable choice and environment).

Note on typical indoor applications for cross-site cable assemblies

In general, fibre optic cables installed in an indoor environment are not exposed to the severe mechanical and environmental conditions that are experienced in the outdoor environment. They are usually protected within the confines of cable ducts (including riser applications), plant room and various other climate-controlled indoor environments.

Note on typical outdoor applications for cross-site cable assemblies

Fibre optic cables installed in an outdoor environment are exposed to more severe mechanical and environmental conditions than are experienced in the protected, climate-controlled indoor environment. Outdoor installations (usually lashed aerially, pulled through duct, or directly buried in the ground) are subjected to combinations of ultraviolet (UV) radiation, standing water, ice, cable-gnawing rodents, temperature extremes and other outdoor-specific hazards.

For normal external horizontal runs of fibre that do not exceed 3m in a vertical run, PPM recommends the use of its loose-tube jelly filled fibre optic cable in order to make the tube in which the fibre(s) reside longitudinally and transversely watertight.

As the jelly in this cable is fairly viscous, PPM offer a loose-tube non-jelly filled alternative for external riser applications that exceed 3m in height.

Cross site Fibre optic Cable specification table					
Environment	INDOOR			OUTDOOR	
Description	Tight buffered, secondary coated, non metallic multi core			Loose tube (jelly filled), glass armoured single core	Loose tube (non-jelly filled), glass armoured single core
Number of Fibres per Cable	4 fibres	8 fibres	12 fibres	12	12
PPM part number	93228	93230	93231	93227	93233
Jacket diameter (mm)	5.0	6.0	7.0	8.5	8.5
Tight tube diameter (mm) with 1 fibre each	0.9	0.9	0.9	N/A	N/A
Weight (kg/km)	28	33	52	82	58
Tensile load (N)					
• during installation	1200	2400	3000	3000	3000
• in service	400	800	1000	1500	1500
Min bead radius (mm)					
• during installation	100	120	130	130	130
• in service	50	60	70	80	85
Crush resistance (N/cm)					
• during installation	1800	1800	1800	400	400
• in service	300	300	300	200	200
Temperature range ©					
• during installation	-10 to +50			-10 to +50	-5 to +50
• in service	-20 to +70			-40 to +70	-5 to +60
• in storage	-25 to +70			-45 to +70	-5 to +60
Number of connectors per end	Between 4 and 12 (dependant on cable choice and part numbering specification)			Between 2 and 12 (dependant on part numbering specification)	
Jacket	Self extinguishing LSFH, very low fire load for high safety			UV resistant, self extinguishing LSFH, longitudinal/ transverse watertight, Rodent resistant	UV resistant, self extinguishing LSFH, Rodent resistant
Fibre type	Single-mode 9/125µm SMF 28				
Connector types available	FC/APC, E2000 (APC)				
Fire propagation	LSFH to IEC 60332-1				
Length	From 25m to 2km. Please contact PPM Sales				

- PPM part numbering system (terminated cross-site assembly)

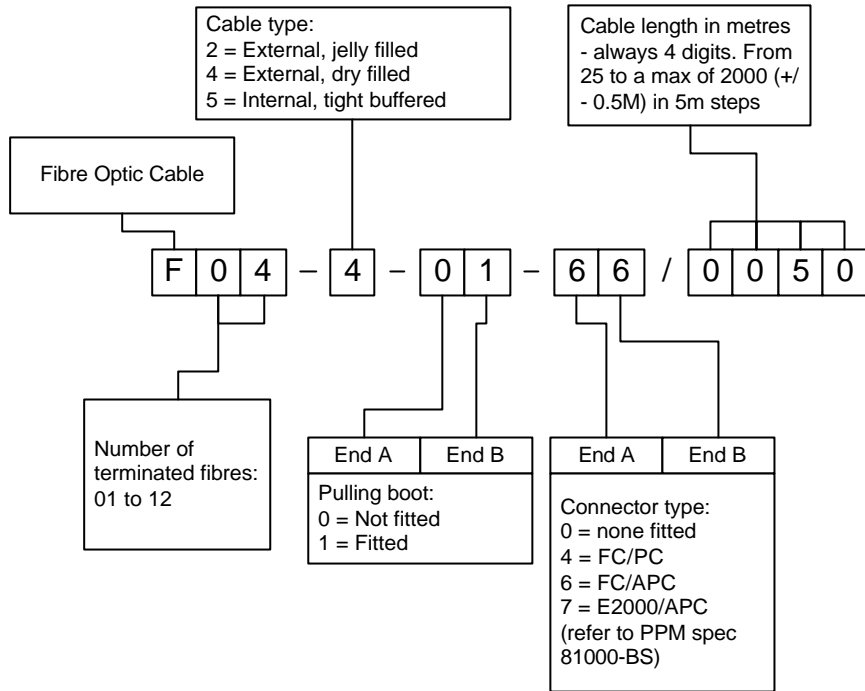

The above example (**F04-4-01-66/0050**) is for a 50m length external jelly-filled cable assembly, terminated each end with 4 FC/APC connectors, and with a pulling boot on one end

- PPM part numbering system (un-terminated loose cable)

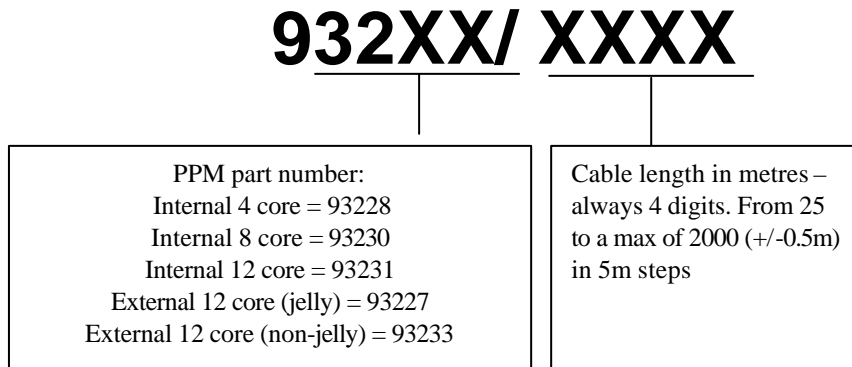

Cable termination boxes (CTB):

To facilitate the complete installation of either of the cross-site cables (terminated or un-terminated), PPM offers three application specific 19" 1U high pressed aluminium cable termination boxes, each capable of accepting a maximum of 24 fibre optic adapters (based upon using two 12 way fibre optic Cables).

Using the basic CTB part number (refer to matrix below), customers can order a set of parts that exactly matches and compliments the fibre management requirements applicable to the fibre cable as selected.

CTB's for fully terminated cross-site cable assemblies

The "plug-n-play" theme is continued with this CTB when used in conjunction with fully terminated cross-site fibre optic cable assemblies fitted with pulling boots, as no drilling is required to fit and tether the cable into position.

Each pulling boot on the assembly is connected onto a moulded gland/ shoulder on the outer sheath of the cable and is easily removable after installation. This moulded shoulder incorporates the main strength member into its construction to take the full tensile load during deployment. The shape of the shoulder corresponds with a cut-out in gland-plate **29098**, into which the shoulder of the cable is "slotted" and thus held captive, mitigating the need for cable gland nuts.

Note : each CTB is capable of accepting two fibre Cable assemblies, therefore any unused positions should be covered with blank gland-plate **29114**.

Because terminated Cable assemblies are factory terminated with the customers preference to a specific optical connector, no on-site splicing of optical pig tails is necessary. Therefore terminated loose leads of the Cable can be quickly and neatly dressed around to the correct number of optical adapters on the internal face of the optical mating panel of the CTB.

Simply select the correct number and type of optical adapters to suit the terminated Cable and correspondingly select the appropriate number of "blanking" caps to neatly dress any vacant positions.

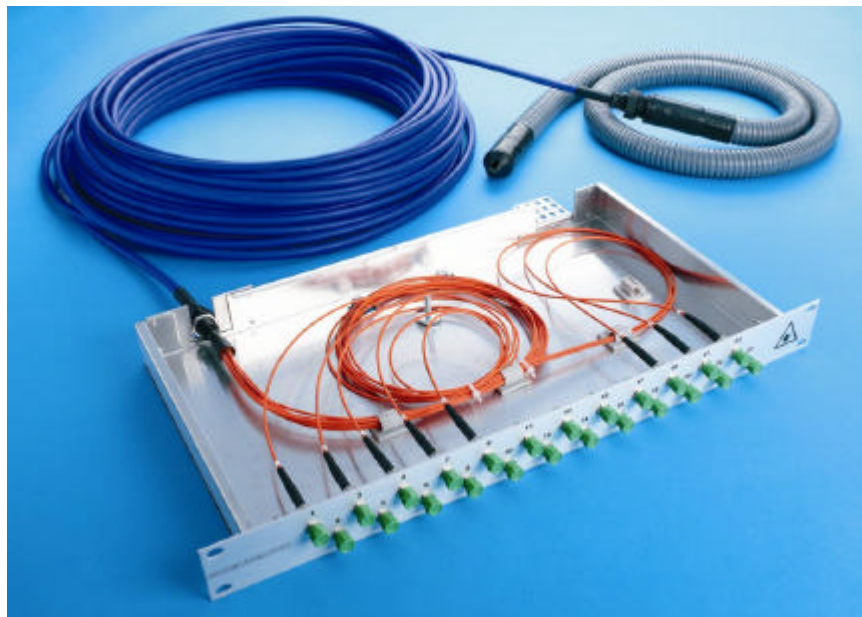

CTB basic part numbers		
Product Family	Optical termination	
	FC/APC	E2000/APC
ViaLite	75006	75007
point2point	75008	
<i>all CTBs supplied complete with fixing hardware to install into any standard 19" cabinet</i>		

CTB's for un-terminated loose Cables

The same basic CTB is employed for un-terminated cables as is utilised for fully terminated cross-site cable assemblies, except for the addition of a dedicated fusion splice management tray.

The splice and fibre optic cable management tray is mounted within the CTB and is designed to assist the installation Engineer neatly dress and secure fusion spliced patchleads (refer to patchlead matrix for part numbers) into position whilst maintaining an adequate bend radius.

In order to anchor the main cable into position, it is necessary for the customer to select the appropriate gland plate(s) and associative cable gland nut from the CTB accessory parts list matrix on the next page.

CTB accessories	
Gland plates <i>(2 required per CTB)</i>	29098 <i>(for fully terminated cross-site cable assemblies)</i>
	29099 <i>(for un-terminated loose cables)</i>
	29114 <i>(for blanking off unused cable position)</i>
Gland nut <i>(for un-terminated cables only)</i>	92210 <i>(PG11 – suitable for 5-10mm cable diameters)</i>
Optical Adapters <i>(for insertion into optical mating panel)</i>	56172 FC/APC <i>(complete with dust caps)</i>
	56181 E2000 <i>(dust caps integral to adapter)</i>
Blanking caps <i>(to blank vacant positions on optical mating panel)</i>	50061 <i>(FC/APC)</i>
	50062 <i>(E2000)</i>
Fusion splice management tray <i>(capable of accepting 24 fusion splices)</i>	50063 <i>(only for use on un-terminated loose cable)</i>
<i>All fixing hardware supplied with basic CTB</i>	

CONTACT US

For further details of this or any other product from PPM, please contact us at:

PPM Ltd, 65 Shrivenham Hundred Business Park, Watchfield, Swindon, Wiltshire, SN6 8TY, UK.

Email: sales@ppm.co.uk, Tel.: +44 (0)1793 784389 Fax: +44 (0)1793 784391

Web: www.vialite.co.uk or www.ppm.co.uk